



A Rockwell Automation Company

Jansen Combustion & Boiler Technologies MacMillan Bloedel Ltd Alberni Pulp & Paper Division

The Client:

Located in Washington State, Jansen Combustion & Boiler Technologies is a mechanical engineering firm specializing in boiler performance improvement. They provide engineering services for all aspects of boiler upgrade and maintenance. One sub-specialty is the design of improved air and fuel delivery systems for power and recovery boilers. The resulting performance increase includes higher steaming rates, improved efficiency, and when applied to recovery boilers, a higher liquor throughput.

MacMillan Bloedel Limited operates a number of pulp and paper mills including their Alberni Pulp & Paper Division (ALPULP), Port Alberni, BC. Changes in pulp and/or paper markets combined with an increase

in production efficiency by the competition necessitated improvements at the ALPULP site. The planned production refinements required an increased black liquor throughput and efficiency in #3 recovery boiler to facilitate the de-commissioning of #2 recovery boiler.

Hinz has established an excellent working relationship with Jansen Combustion & Boiler Technologies and was requested by them to provide a complete solution for the power and control systems upgrades. Hinz worked closely with Jansen Combustion & Boiler Technologies in all aspects of the electrical, instrumentation and control system design.

The Requirement:

The recovery boiler upgrade included a completely re-engineered air system which included boosting the forced draft (F.D.) fan output, modifying the wind boxes and changing the delivery of the primary, secondary, and tertiary air through patented Jansen air nozzles. The changes to the liquor system centered

around increasing the solid content of the liquor, by replacing the direct contact black liquor heater with an indirect liquor heating. Modifications to the liquor nozzles were made to improve distribution of the liquor, resulting in further improvements in firing.

The Design Solution:

The upgrade required additional fans and pumps to increase the throughput of air and black liquor. Additional instruments and control devices were required to closely monitor and control the process.

During the project engineering design stage, Hinz worked closely with ALPULP to produce a design that was to mill standards.

PLCs were implemented to control the various discrete signal portions of the process. The black liquor safety and burner management (auxiliary fuel) systems were controlled by one PLC. A second PLC was used to control the non-safety systems (fans, motors, etc.). The processes' analog signals were controlled by stand alone controllers.

The process controls were linked by a supervisory MMI system to provide a graphically displayed operator control and monitor station. A total of five screens were designed and developed to facilitate a user-friendly control environment.

Hinz provided complete Electrical Engineering services including system design, equipment procurement, and commissioning. The changeover was commissioned in four weeks. The operator's transition from the previous pneumatic controls to the new microprocessor based stand alone controllers and the MMI was well received.



A Rockwell Automation Company

Jansen Combustion & Boiler Technologies MacMillan Bloedel Ltd Alberni Pulp & Paper Division

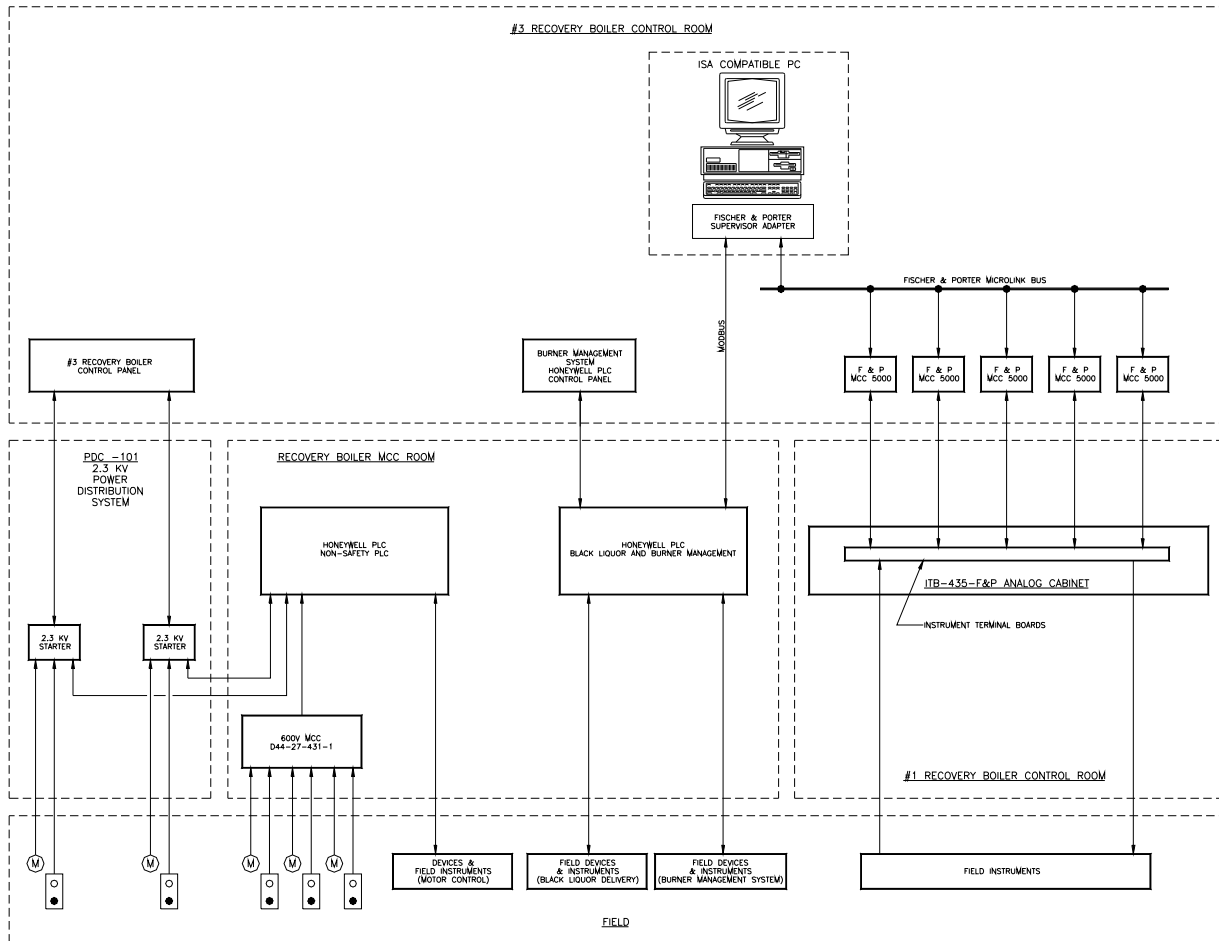

System Specifications:

- PLC - Honeywell
- MMI - Screenware
- Loop Control - Fisher & Porter

For further information or to contact a Hinz office near you, please check our website at:

www.hinz.com