



A Rockwell Automation Company

Amber Energy Inc. VFD Synchronous Transfer

The Client:

Amber Energy Inc. is developing its heavy oil resources in the Pelican Lake area north of Wabasca. Amber Energy Inc. has extensive oil reserves in the region. The Pelican Lake deposits reach as far north

as Fort McMurray. As a result, Amber Energy has long term plans for their heavy oil production in Pelican Lake.

The Requirement:

Oil produced in Pelican Lake required a more cost-effective method than trucking to reach the available market in Edmonton. A pipeline connecting Amber Energy's Pelican Lake terminal to Peace Pipeline Ltd. was required. Peace Pipeline ships to Edmonton where the oil is sold to the local refineries or transported by other pipelines to the major East Coast American markets.

Peace Pipeline's SCADA controls needed to monitor/operate the Amber Energy Station. To facilitate oil transport, installation of four pump-motor

combinations was required. A weak power grid at such a remote site and energy savings from eliminating pressure throttling deemed a Variable Frequency Drive (VFD) necessary. Since the site required four mainline pumps and the cost of four VFDs was significant, a transfer program was necessary. The control system allowing for synchronous running transfer of units from the VFD bus to bypass bus, and back to the VFD bus, was to be provided by Hinz. The ability to switch a running motor-pump combination from/to the VFD to/from bypass allows all four motor pump combinations to be controlled by a single VFD.

The Design Solution:

Hinz was hired by Upside Engineering Ltd. and Amber Energy Inc. to provide the VFD bypass transfer PLC program. Hinz provided the detailed design, synchronous transfer controls equipment specifications, controls programming, testing, field support, commissioning, and documentation. The Perfect Harmony voltage sourced Variable Frequency Drive from Robicon Canada Ltd. was selected at the start of the project. The synchronous transfer program PLC was chosen to be a Modicon Quantum controller, because the Robicon VFD can complete transfer communications via a Modbus plus link. The Modicon PLC automation equipment was specified by Hinz. The PLC I/O layout was also determined by Hinz.

After creation of the PLC programs was tested on the Sutherland and Shultz PICS program before being installed on-site. The program allowed Hinz to simulate the field I/O, resulting in comprehensive program testing. The synchronous transfer program was commissioned on-site by Hinz, whereby all the motor VFD and bypass contactors were tested. The time frame during transition from VFD to bypass and bypass to VFD were accepted by Robicon and then the station was placed into active service.



A Rockwell Automation Company

Amber Energy Inc. VFD Synchronous Transfer

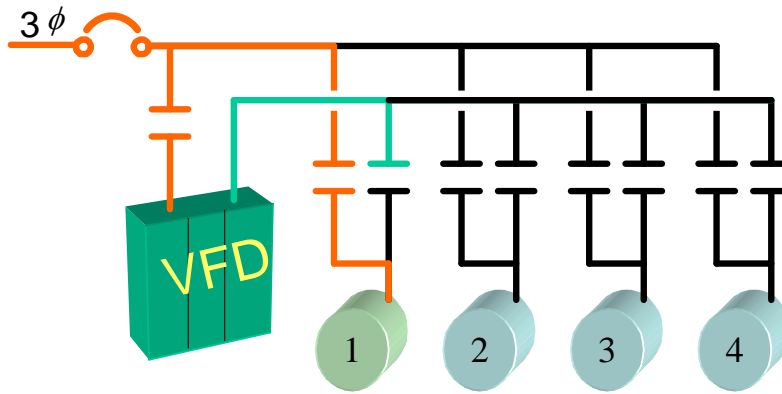

Control System Overview

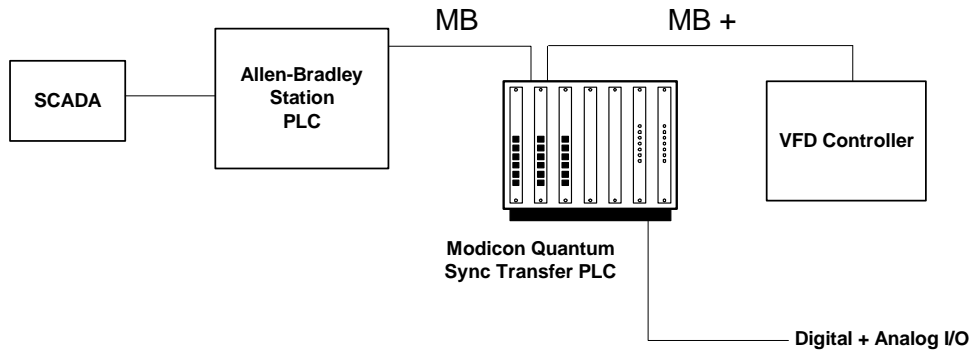

System Specifications:

- Modicon Quantum PLC BM-85 and RR*85's
- Robicon Variable Frequency Drive

For further information or to contact a Hinz office near you, please check our website at:

www.hinz.com