



A Rockwell Automation Company

Enbridge Pipelines White City Modifications

The Client:

Enbridge operates the world's longest crude oil and liquids pipeline system in Canada and the US. The company owns and operates Enbridge Pipelines Inc. and a variety of affiliated pipelines in Canada and has a 14.1% interest in Enbridge Energy Partners, L.P. which owns the Lakehead System in the U.S. These pipeline systems have operated for over 50 years and now comprise approximately 15,000 kilometers (9,000 miles) of pipeline, delivering more than 2 million barrels per day of crude oil and liquids.

Enbridge is also involved in liquids marketing and international energy projects and has a growing involvement in the natural gas transmission and midstream businesses through the Alliance and Vector pipelines, its investment in AltaGas Services, and various U.S. assets that transport, gather, process and market natural gas and other petroleum products.

As a distributor of energy, Enbridge owns and operates

Canada's largest natural gas distribution company,



Enbridge Gas Distribution, which provides gas to industrial, commercial and residential customers in Ontario, Quebec and New York State. Enbridge distributes gas to more than 1.5 million customers and is developing a gas distribution network in New Brunswick.

The Requirement:

Expansion involved implementation of the Terrace Expansion Project - a phased development that was expected to result in the increase of heavy crude oil deliveries of 520,000 barrels per day, with a net system capacity increase (after allowing for anticipated declines in light crude oil) of 350,000 barrels per day. Phase I was completed in 1999, adding 170,000 barrels per day of capacity. Phase II was completed at the beginning of 2002, adding another 40,000 barrels per day. Phase III was expected to add another 140,000 barrels per day by mid-2003. The Terrace III Expansion project required the following work at the Enbridge White City facility.

The Terrace III Expansion project required the following work at the Enbridge White City facility.

White City was to be reactivated, which required upgrading the substation protection and pipeline control systems. Affected substation equipment included the retrofit of the 72Kv Oil Circuit Breaker control system, addition of transformer differential protection (Multilin 745) and upgrades to the entire substation protective relaying system. Pipeline modifications included upgrading pipeline temperature and pressure monitoring equipment and the upgrade to the unit vibration monitoring system.

The Design Solution:

The Hinz Engineering team provided project management engineering design, procurement and over-all planning. The engineering team worked with Enbridge project engineers and site maintenance people to meet Enbridge's design, budget and schedule requirements. Design package included - station and terminal single and three line diagrams, P&IDs,

equipment layout, protective relay cabinet layout, lighting, grounding, cable and conduit schedules, hazardous location classification, PLC panel layout and I/O loop drawings. Procurements included specification of all 5Kv equipment, sub station 5KV bus fittings, pad-mounted air break switch and station services, and all instrument data sheets and selection.



A Rockwell Automation Company

Enbridge Pipelines White City Modifications

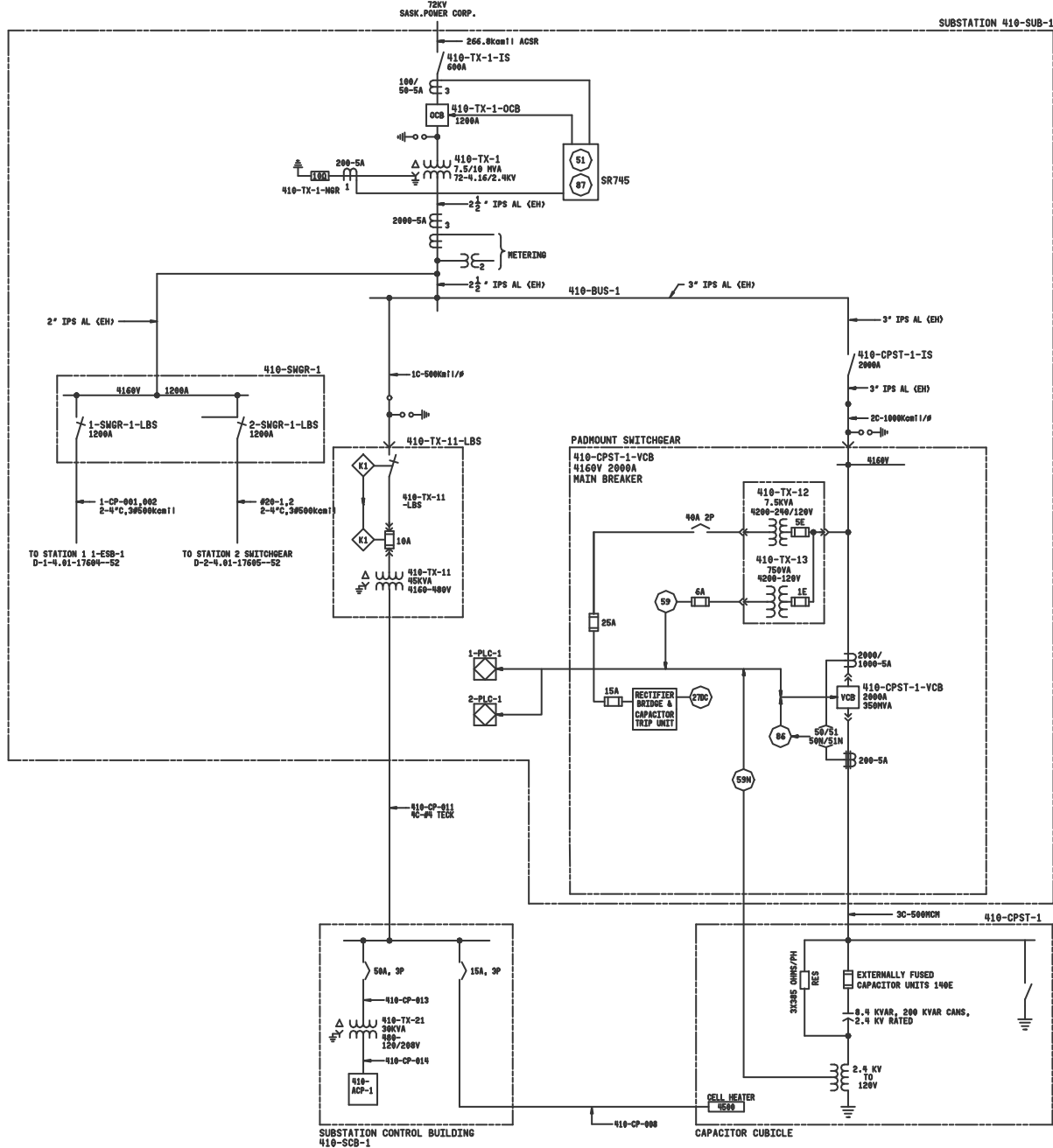

For further information or to contact a Hinz office near you, please check our website at:

www.hinz.com