



A Rockwell Automation Company

## Robicon Canada Ltd./AEC Pipelines VFE Synchronous Transfer

### The Client:

Robicon Canada Limited, a subsidiary of High Voltage Engineering Corporation, manufactures a diverse range of electronics-based power equipment and system solutions. The U.S.-based company has installations in 57 countries and takes pride in providing excellent customer service and support.

AEC Pipelines is a subsidiary of the Alberta Energy Company Ltd. (AEC). Its pipelines transport oil throughout Alberta via the Cold Lake, Wabasca, and Alberta Oil Sands Pipelines. AEC Pipelines also operates the Express and Platte Pipelines in the Northern United States.

### The Requirement:

The Cold Lake area has an enormous resource basin that, when combined with Alberta's other oil sands deposits, contains more petroleum than all the oil fields of Saudi Arabia. The Cold Lake Pipeline allows shipment of oil from major producers in Northeastern Alberta to Edmonton and other potential market centers. Pipeline control consists of pump and motor operation and strict monitoring at pumping and metering stations along the pipeline.

SCADA controls will monitor and operate the Cold Lake AEC Pipeline. To facilitate oil transport, installation of three motor-pump combinations was required. The sites for pipeline control are located in remote areas with weak

power grids. A Variable Frequency Drive (VFD) was deemed necessary because it can compensate for a weak power grid and provide energy savings by eliminating pressure throttling. Since the site required three mainline pumps and the cost of three VFDs was significant, a transfer program was necessary. The transfer program allows a running motor-pump combination to be switched to/from the VFD and to/from the utility line. Essentially this allows all three motor-pump combinations to be controlled by one VFD. The control system allowing for synchronous running transfer of units from the VFD bus to bypass bus and back to the VFD bus was to be provided by Hinz.

### The Design Solution:

Hinz was hired by Robicon for AEC to provide the control system for two sites along the AEC Cold Lake Pipeline. Hinz provided the detailed design; synchronous transfer controls equipment specifications; synchronous transfer programming; in-house and factory testing; field support; on-site commissioning, and documentation.

The client was actively involved in equipment selection and chose the Perfect Harmony Next Gen voltage sourced Variable Frequency Drive supplied by Robicon Canada Ltd. The synchronous transfer program programmable logic controller (PLC) was chosen to be a Modicon Quantum controller to comply with AEC standards. This controller is referred to as the VFD PLC. Hinz selected the QuickPanel HMI because of its simplicity and value. The HMI allows maintenance personnel to have local control of the site. The HMI also displays trips and alarms to assist with on-site commissioning and troubleshooting by maintenance personnel. A Modbus link between the VFD and the VFD PLC communicates

trips, alarms and analog data. Controls between the Quantum PLC and VFD are via hardwired I/O to allow for high-speed data transfer and ensure data integrity.

Preliminary testing of the PLC and VFD occurred at the Robicon factory in Pittsburgh. This testing allowed Robicon, Hinz and the client to finalize and test the trips and alarms that would be displayed and the operation of the synchronous transfer program. This factory testing was designed to reduce the on-site commissioning time.

Hinz commissioned the synchronous transfer program on-site. Commissioning consisted of testing all alarm points and ensuring that all three motor-pump combinations can be transferred to/from the VFD and to/from the utility supply. The time frame during transition from VFD to bypass and bypass to VFD were accepted by Robicon and then the stations were placed into active service.



A Rockwell Automation Company

## Robicon Canada Ltd./AEC Pipelines VFE Synchronous Transfer

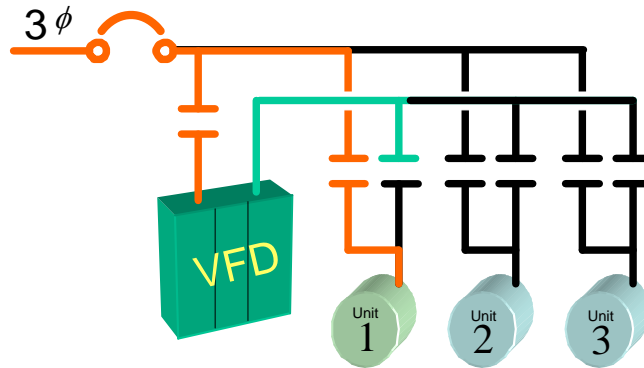

### Control System Overview

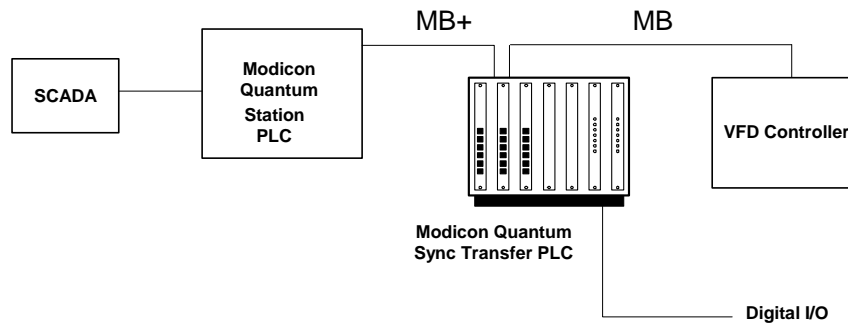

### System Specifications:

- The Robicon Perfect Harmony Next Gen voltage sourced variable frequency drive (VFD) was used to ramp up the three motor-pump combinations on site.
- A QuickPanel was chosen as the Human Machine Interface (HMI) to allow local control, monitoring and troubleshooting via trip and alarm display.
- A Modicon Quantum programmable logic controller (PLC) was chosen as the VFD PLC to control the system.
- The VFD and VFD PLC communicate via Modbus. Controls between the VFD and VFD PLC were via hardwired I/O.

For further information or to contact a Hinz office near you, please check our website at:

[www.hinz.com](http://www.hinz.com)