



A Rockwell Automation Company

KN Energy Scott City RealFlex Upgrade

The Client:

KN Energy operates a natural gas pipeline collecting gas from wellheads in Colorado, Kansas, Nebraska, Oklahoma and Texas and delivering the gas to end users and wholesale customers. The Scott City station,

located just west of Scott City, Kansas, is a Helium extraction plant and a pipeline compressor station.

The Requirement:

The original RealFlex system was a relatively simple data collection system. It had been initially configured a number of years earlier by other personnel. The RealFlex software and the PC computer hardware were in need of upgrade.

Recognizing the potential of the RealFlex system for additional data collection and reporting, KN Energy decided to expand the capabilities to include control of the compressors.

The ability to change the compressor suction and discharge valves without stopping the compressors was to be implemented.

Additional data collection and reporting from the flow computers and gas chromatographs was also to be added.

Reporting from the PLC based station fault panel to the control room operator was to be added to the system.

A remote compressor station, 25 miles away was unmanned for much of the time. Remote monitoring of that station was also to be incorporated into the system.

The Design Solution:

The first step was to upgrade the operating system to the current Windows version of QNX and RealFlex, and to implement the system on 90MHz Pentium PCs with larger monitors. These computers were purchased with future system expansions in mind.

New data points were added to the database for six Daniel's SolarFlow computers, two Daniel's Gas Chromatographs, an Allen-Bradley PLC 5/15 that runs the station fault panel, and three additional Entronics compressor control panels. Drivers for the above interfaces were configured and deployed.

Individual reports for hourly compressor status and fuel consumption were developed. To replace the manually generated daily reports on flow and composition, custom reports were developed for the flow computers and gas chromatographs. .

The compressor panels are capable of remote auto start and stop commands, and set point adjustment for flow and pressures. An operator interface was developed in the RealFlex system to connect the operator to the hardware remotely. Additional work was done with the compressor panel vendor to add remote valve sequencing capabilities into the control for the compressors. An interface was built for changing the valve configuration without stopping the compressor. The interface had to accommodate requirements for compressor sequencing.

A BJscan link to a remote compressor station at Syracuse was developed. The Entronics panel compressor control data and flow computer data was brought back from that location.



A Rockwell Automation Company

KN Energy Scott City RealFlex Upgrade

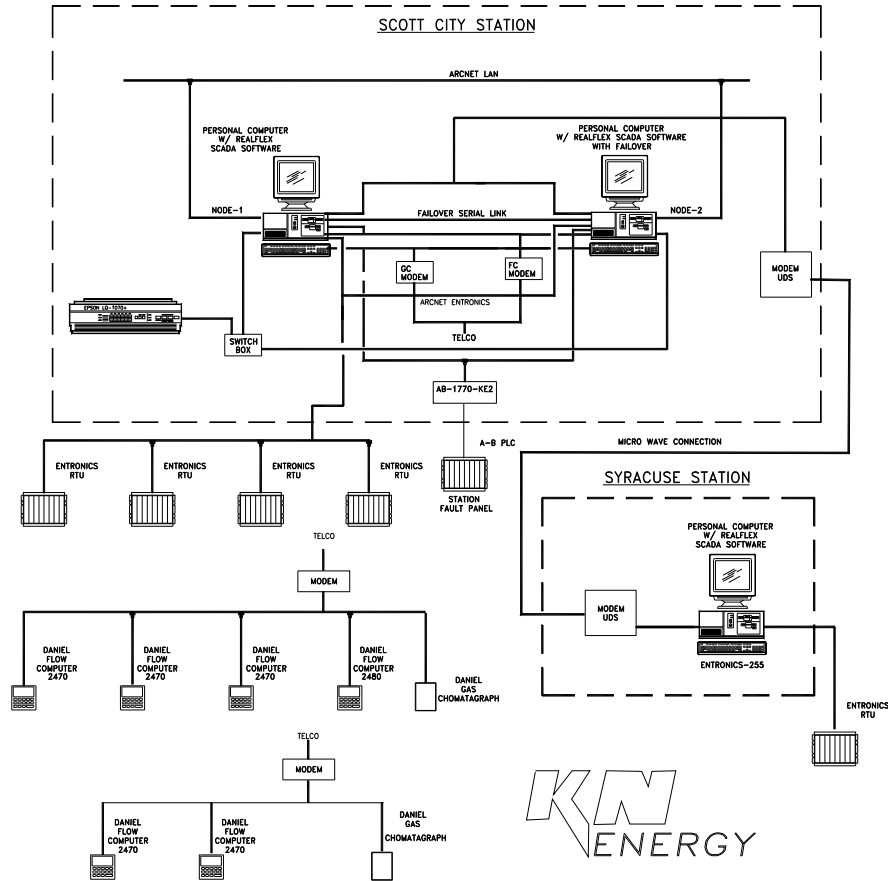

System Specifications:

- QNX 2.3 for Windows
- RealFlex Windows Ver 1.2 with:
 - Wftscan
 - Wdanscan
 - Wdsiscan
 - Wabdf1scan
 - Wbjscan/Wbjremote
- 2 - 90mhz Pentium computers
 - 16 Mbyte RAM
 - 500 Mbyte hard drives
 - 21 inch monitors

For further information or to contact a Hinz office near you, please check our website at:

www.hinz.com