



A Rockwell Automation Company

Albian Sands Energy Muskeg River Mine Flare Safety System

The Client:

The Muskeg River Mine, operated by Albian Sands Energy, is located 75 km North of Fort McMurray, Alberta. The mine produces 155,000 barrels per day of bitumen which is diluted and transported via pipeline 493 km to the Scotford Upgrader located in Fort Saskatchewan, Alberta. The mine and upgrader are owned by Athabasca Oil Sands Project (AOSP), a joint venture of 60% Shell Canada, 20% Chevron Canada, and 20% Western Oil Sands.

As a 60% majority owner, Shell Canada has a significant influence on Albian standards and technical design practices. Hinz has worked closely with Shell Canada in designing safety systems for their upstream and refining facilities. The Flare Safety System upgrade is Hinz's first project for Albian.

The Requirement:

Albian Muskeg River Mine required an additional layer of safety protection for three areas connected to their flare system: Froth Treatment Areas 250 and 270, plus Solvent Recovery Unit Area 260. The High Integrity Pressure Protection System (HIPPS) project provides over-pressure and vessel over-filling protection. HIPPS provides a safety layer in addition to the existing ControlLogix PLC-based SIS.

Required HIPPS system features included:

- Enhanced safety integrity.
- Moving of some safety functions from the existing SIS\DCS to the HIPPS system.
- One redundant SIL 2 ControlLogix safety PLC to be installed in existing SIS panel located in the Area 250 E-House.
- Second redundant SIL 2 ControlLogix safety PLC to be

installed in existing SIS panel located in the Area 270 E-House.

- PanelView local HMI in the two E-Houses.
- Connection to existing Foxboro DCS via existing SIS gateway PLC.
- Interface to initiate shutdown sequencing within the existing Chiller Compressor ControlLogix PLC.
- Initiate shutdown of SRU Column Overflow Pumps on high level
- Existing PCS PLC to read HIPPS trips and then set controller outputs to zero.
- Time synchronizing of HIPPS to the existing SIS system

The Design Solution:

Hinz designed, specified, programmed and tested two ControlLogix PLCs with redundant processors and I/O. The HIPPS system uses ControlNet communications and is integrated into the existing ControlNet system. The design solution will provide the IPF SIL specifications required without degrading the plant's overall reliability.

Hinz work scope included:

- Development of the HIPPS Systems Requirements Specification following the Shell SIS Design Engineering Practices.
- System design and integration and system architecture additions.
- Specification of the redundant Rockwell ControlLogix PLCs, IO cards, networking devices and cables, and electrical equipment and wiring materials for procurement by Albian.
- Electrical design, drawings, and Construction Work Package
- HIPPS PLC programming and testing.

- On-site system testing and commissioning including interfaces to existing SIS, PCS PLCs, the DCS, and Chiller Compressor vendor PLC.

Notable design features include:

- Each redundant HIPPS PLC installation is housed in a single rack with 2 ControlNet Communications Modules (CNBRs) with redundant I/O split between the two CNBRs.
- Pulse testing is used to supervise the HIPPS Outputs.
- The primary shutdown path is implemented via an OB16D Diagnostic Output module. A pulse test routine verifies the integrity of the final elements and loop integrity. When a problem is detected an operator maintenance alarm is sent to the DCS
- A secondary shutdown path is implemented via an isolated Digital (Relay) Output module (1756-OW16). The relay contact opens when there is a demand to trip and a diagnostic fault is present on the primary shutdown channel



A Rockwell Automation Company

Albian Sands Energy Muskeg River Mine Flare Safety System

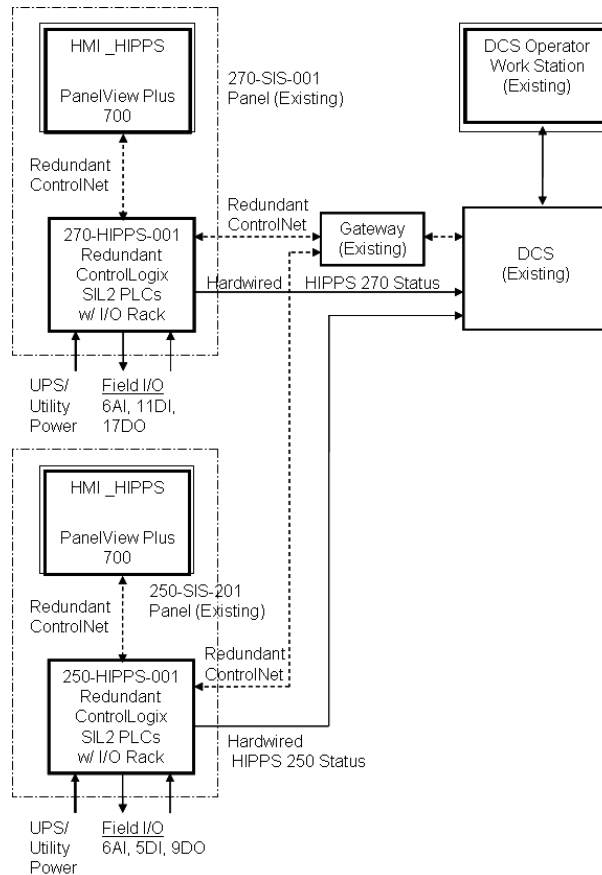

System Specifications:

- (2) 2711P-B7C15B2 PanelView Plus 700 Keypad and Touch Screen
- (4) 1756-A13 ControlLogix 10 slot Chassis
- (4) 1756-A10 ControlLogix 7 slot Chassis
- (6) 1756-PAR2 Redundant Power Supply Bundle
- (4) 1756-L63B ControlLogix CPU
- (4) 1756-SRM ControlNet Redundancy Module
- (8) 1756-CNBR ControlNet Redundant Communications Module
- (4) 1756-ENBT Ethernet Module
- (4) 1756-IF16 16 Channel Analog Input Module
- (4) 1756-OW16 16 Channel Relay Output Module
- (4) 1756-OB16D 16 Channel DC Diagnostic Output Module
- (2) 1756-IB16I 16 Channel DC Isolated Input Module
- (2) 1756-IB16D 16 Channel DC Diagnostic Input Module

For further information or to contact a Hinz office near you, please check our website at:

www.hinz.com