



A Rockwell Automation Company

## Estevan Coal Dragline Monitor

### The Client:

Estevan Coal Corp., a division of Luscar Ltd., operates the Bienfait Mine, an open pit lignite coal operation near Estevan, Canada. The mine operates a total of 2 draglines, and has a production capacity of 1.5 million

metric tons per year. The carbonization plant has an annual capacity of 100,000 metric tons of lignite char. The coal is primarily sold to Canadian markets.

### The Requirement:

Estevan coal required a dragline monitor to provide a single comprehensive source of dragline data which would be usable by the operating, maintenance and supervision staff at the mine. The system was expected to:

- Increase Production by reducing unnecessary delays
- Improve maintenance effectiveness by providing more accurate and complete data on dragline performance

- Provide accurate and unbiased data required for equipment evaluation from various manufacturers.

In order to meet these objectives at minimal cost they attempted to implement a system using a custom microprocessor board designed in-house. This proved to be far more expensive than anticipated and it was difficult to make adjustments and improvements. Hinz was approached to find a solution that would be easy to use and maintain, while still providing the flexibility for changes and additions in the future.

### The Design Solution:

After evaluating a number of alternatives it was decided that a PLC based system would provide the needed functionality in the most flexible and economical package. The Allen Bradley PLC was chosen because the site personnel were already familiar with it. The system consists of a 5/15 programmable controller, an Allen Bradley PanelView operator interface and a 1771-DB Basic module with a printer for printing reports.

The operator uses the PanelView to view the dragline monitoring data as well as to input certain data. Each time there is a change in the operational status of the dragline the operator enters on the PanelView an operator ID, and a code for one of several operation or delay categories. Operation categories include overburden, bench, re-handle, mud, walk, and other. Delay categories include service, equipment, weather, power, thaw bucket, teeth, electrical repair, mechanical repair, ropes, and bucket. The operator has a continuous display of all run time totals available for

each category, as well as statistics such as total buckets, average buckets per hour, Bank cubic meters (BCM) per hour, last cycle time, average cycle time, last swing angle, average swing angle, motor run times, and total rope travel Reports are also printed for shift and month end, as well as on demand.

The tracking system uses swing position & motion, drag position, motion, & pull, and hoist position, motion & pull as criteria for valid cycles. Drag and hoist positions are measured directly from absolute encoders on the rope drums. The swing position is also measured by an encoder value, which has gear ratio compensation. The drag and hoist pulls are calculated based on armature currents. Each criteria has one or more preset values which are used depending on the step in the cycle (e.g. swing motion has to be below a preset value before and during digging), and the operation code (e.g. drag armature current is set lower while benching).



A Rockwell Automation Company

## Estevan Coal Dragline Monitor

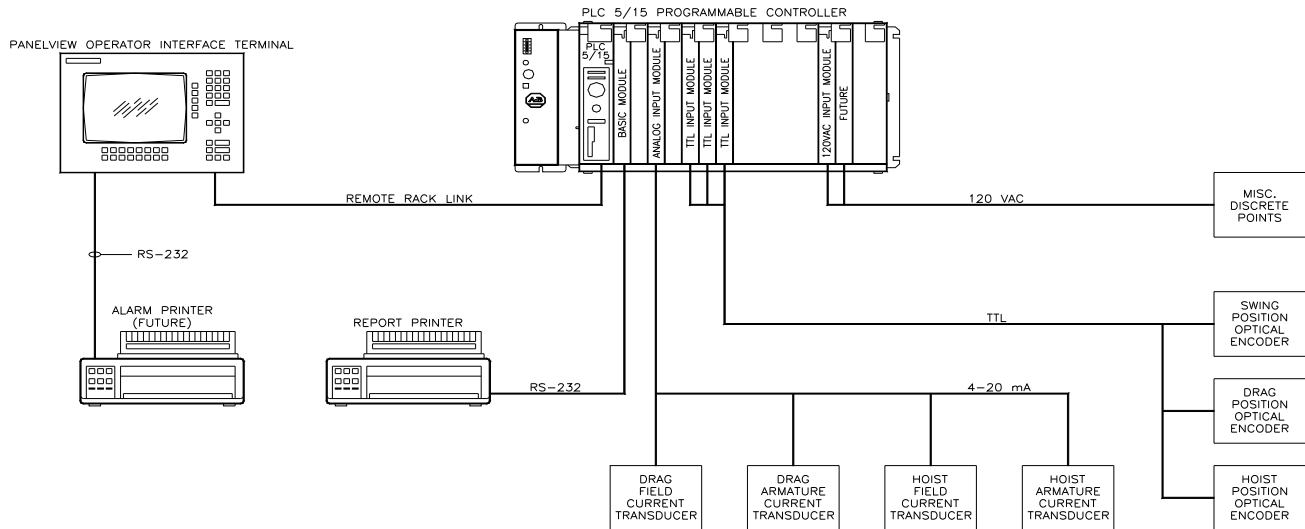

### System Specifications:

- Allen Bradley PLC 5/15
- Analog, TTL and Discrete I/O
- PanelView MMI with 2 graphics pages
- Shift report - 109 variables
- Monthly report - 49 variables

For further information or to contact a Hinz office near you, please check our website at:

[www.hinz.com](http://www.hinz.com)