



A Rockwell Automation Company

Alchem Industries Ltd. Expansion Project

The Client:

Alchem is a major provider of sodium chlorate, which is used in the production of high-grade pulp. Alchem mines the salt, then uses an electrolysis process and a

variety of support processes to create sodium chlorate crystals.

The Requirement:

Alchem Industries contacted Hinz to provide Electrical, Instrumentation, Control Engineering and Commissioning Assistance on their 2000T Expansion Project. Process design was lead by the parent company Krebs from their head office in Montigny-le-Bretonnex, France. Walter Chambers and Associates of Edmonton provided the plant

Structural Engineering component.

This required an extraordinary effort in maintaining project communications and document transfers. This was truly an International project.

The Design Solution:

Engineering Design included all aspects of Electrical, Instrumentation and Control required to complete the Alchem's Expansion Project. The design team consisted of a Project Manager, Power System Engineer, Electrical Designer, Instrumentation Designer and a Systems Engineer. We expended over 4000 man-hours and issued over 400 electrical drawings during a project schedule of just over 8 months. The five member design team originally evaluated the existing plant electrical systems, making recommendations and implementing the necessary changes to the 138kV, 13.8KV, 600V and Emergency Power Systems.

The 13.8kV power distribution modifications included the addition of a 20MVA power transformer and rectifier system supplied by Fuji; breaker additions to the existing 13.8kV Switchgear; substation modifications to metering facilities and an addition of a new Harmonic Filter Bank supplied by TAU. The DC Bus system layout and capacity of 155,000 Amps was also reviewed and verified for structural and electrical integrity.

Plant additions also included over 1000kVA in low voltage motor loads including the installation of 2 - 100HP VFDs and 2 - 200HP cooling water pumps. This required the upgrade of the plants 13.8kV/600V 3000kVA Distribution Transformer to 4000kVA and modifications to the 600V Main Distribution Switchgear. A new electrical MCC room was added to contain the new 600V Motor Control Center (11 Sections), 600V VFDs, all 347V and 120V Lighting and Power Distribution Panels,

and a Fischer ProVox DCS control cabinet.

An additional 350KVA emergency diesel generator set was specified and installed to supplement the existing systems. This generator is used to provide emergency power upon failure of the 13.8KV feed to the rectifier. Its main purpose is to provide power to a 400Amp DC Polarizer used to protect the process equipment during utility power failures. It provides power to this polarizer via a second Emergency MCC (5 section) utilizing an Automatic Transfer Switch located in the MCC.

A second UPS system (15 KVA @ 120VAC) was also installed to provide clean power to all new instruments and the expanded DCS system. It was also connected to the emergency generator.

A full commissioning plan was also created. Commissioning procedures and check-out sheets for every piece of new or modified equipment were produced. This included construction installation, location layouts, cable tagging, and schematic as-builts, etc. After completing the physical installation check-out each piece of equipment was subjected to a full functional check-out prior to acceptance by the customer. Engineering Design included all aspects of Electrical, Instrumentation and Control required to complete the Alchem Expansion Project. The design team consisted of a Project Manager, Power System Engineer, Electrical Designer, Instrumentation Designer and a Systems Engineer.

(Continued on next page)



A Rockwell Automation Company

Alchem Industries Ltd. Expansion Project

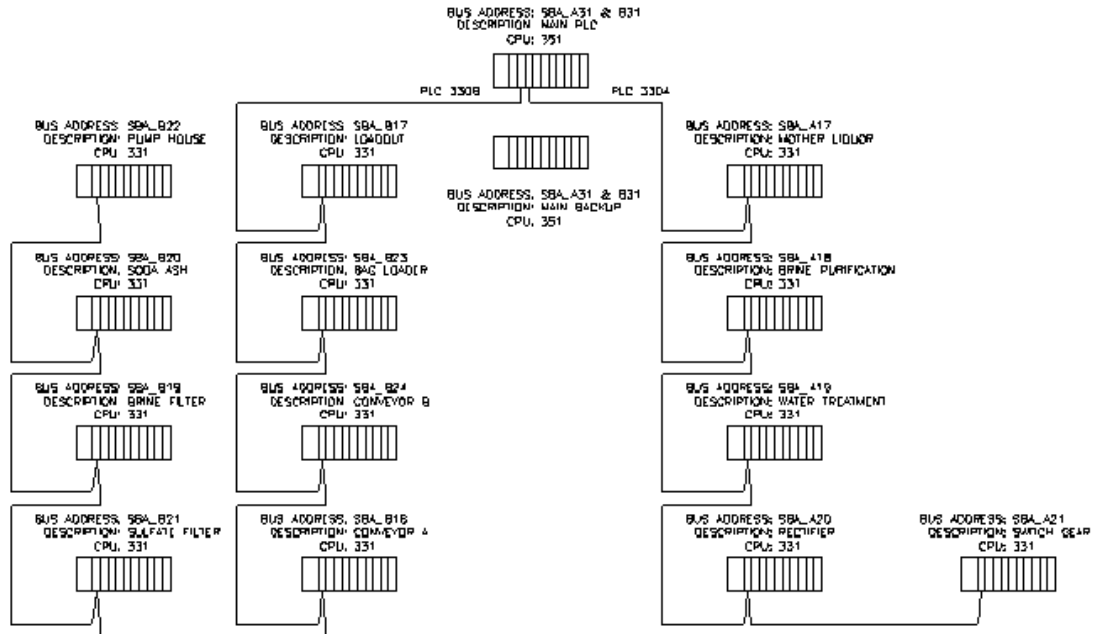

(Continued from previous page)

The Instrument Detailed Design portion encompassed over 275 instruments on 70 P&IDs. This required the generation of over 250 Data Sheets and Instrument Loop drawings, and over 30 instrument layout and installation detail drawings.

Considerable effort was required to transpose European style data sheets, including some translation of French, to ISA format. The first phase involved the translation of hand written data sheets to ISA format. After which, with the considerable number of instruments to be handled an extensive database system was created. This allowed the transfer of pertinent process data between Krebs and Hinz in Microsoft Excel

Spread Sheet format.

With the large number of instruments, one major goal accomplished was the standardization of Instrument Loop drawings: only six different styles of loop sheets were created. This facilitated the use of Hinz's "Project Management Database System" (PMDS). This system is a tool which links multiple databases to populate information on standard AutoCAD drawings. This system was used to create the instrument index, all data and loop sheets, cable schedules, I/O listings for the DCS and cable interconnection drawings.

For further information or to contact a Hinz office near you, please check our website at:

www.hinz.com