



A Rockwell Automation Company

Norbord - Huguley, AL Oriented Strand Board Plant

The Client:

Norbord Industries Inc. is a wholly owned subsidiary of Nexfor Inc., headquartered in Toronto, Ontario. Norbord is a leading international manufacturer, marketer and distributor of wood and wood composite panel products. They employ over 1,300 people worldwide and operate OSB, MDF and plywood mills in Canada, United States

and Scotland. Huguley is Norbord's seventh OSB plant with operations currently in production at Bemidji, Minnesota; Tupelo, Mississippi; Kinards, South Carolina, Val-d'Or, Quebec; La Sarre, Quebec and Inverness, Scotland.

The Requirement:

The Huguley plant has a design capacity of 500 million square feet (3/8 inch basis) annually. It employs an 8 x 181 foot continuous press line and conveyor drying technology. Norbord commissioned a design team with extensive experience in the Oriented Strand Board industry. Industec (a division of UMA Industrial) was selected as the process/mechanical consultant and Hinz was selected as the electrical/controls consultant based on our single discipline specialty nature coupled with specific OSB industry experience.

Hinz' responsibilities included the design, construction, supervision and commissioning of an electrical and control system. This design had to be flexible enough to accommodate multiple vendors, but also needed to keep the number of vendors (and therefore spare parts inventory) to a minimum. Process equipment vendors were from Germany, Canada and the USA, requiring regular communication during the project design.

The Design Solution:

Hinz provided complete electrical and controls engineering services including selection of major electrical and controls hardware, power and electrical design, instrumentation design, specification and supervision of control systems provided by others, HMI configuration, programming of PLC systems, documentation, on-site commissioning and installation supervision.

The Huguley plant has over 800 motors with a connected horsepower of 26,000. The main plant power is supplied from a 110kV - 4.16kV utility substation. The 4.16kV system feeds the 2500kVA substations and motors above 200 HP. 4.16V - 480V 2500kVA unit substations distribute power throughout the plant to the electrical equipment and the motors. MCC layouts were structured according to process areas allowing for fast start-up and check-out of all components as each process area was completed. This approach provided increased flexibility and minimal impact on construction occurring in other areas. All motor control I/O were installed and pre-wired within the MCCs by the MCC manufacturer to minimize errors and expedite the installation and commissioning process. Field I/O was enclosed in remote I/O cabinets and distributed throughout the plant as needed.

The control system configuration necessitated the need for individual PLCs in stand alone process areas based on process independence and vendor supply. Plant control for each area was achieved using an Allen-Bradley PLC 5/20C, 5/40C or 5/80C processor depending on the control requirements. Some of the PLCs were supplied by the process vendors because of the concern over performance guarantees. Communication between the PLCs and the HMIs was achieved using an Ethernet network. A dedicated ControlNet network was used for PLC to PLC, PanelView and I/O communication. The Human Machine Interface (HMI) is based on Allen-Bradley's RSView software package operating on Texas Micro Industrial computers. One control room was dedicated for control of the energy and dryer systems with three RSView stations for control of this area. A second control room was used for control of the press, forming and blending areas of the plant. Four RSView stations were used for the press (by Siempelkamp) and one for the blending and dust systems. In addition to the HMI stations in the control rooms, Allen-Bradley PanelViews with TouchScreens are used in the field.



A Rockwell Automation Company

Norbord - Huguley, AL Oriented Strand Board Plant

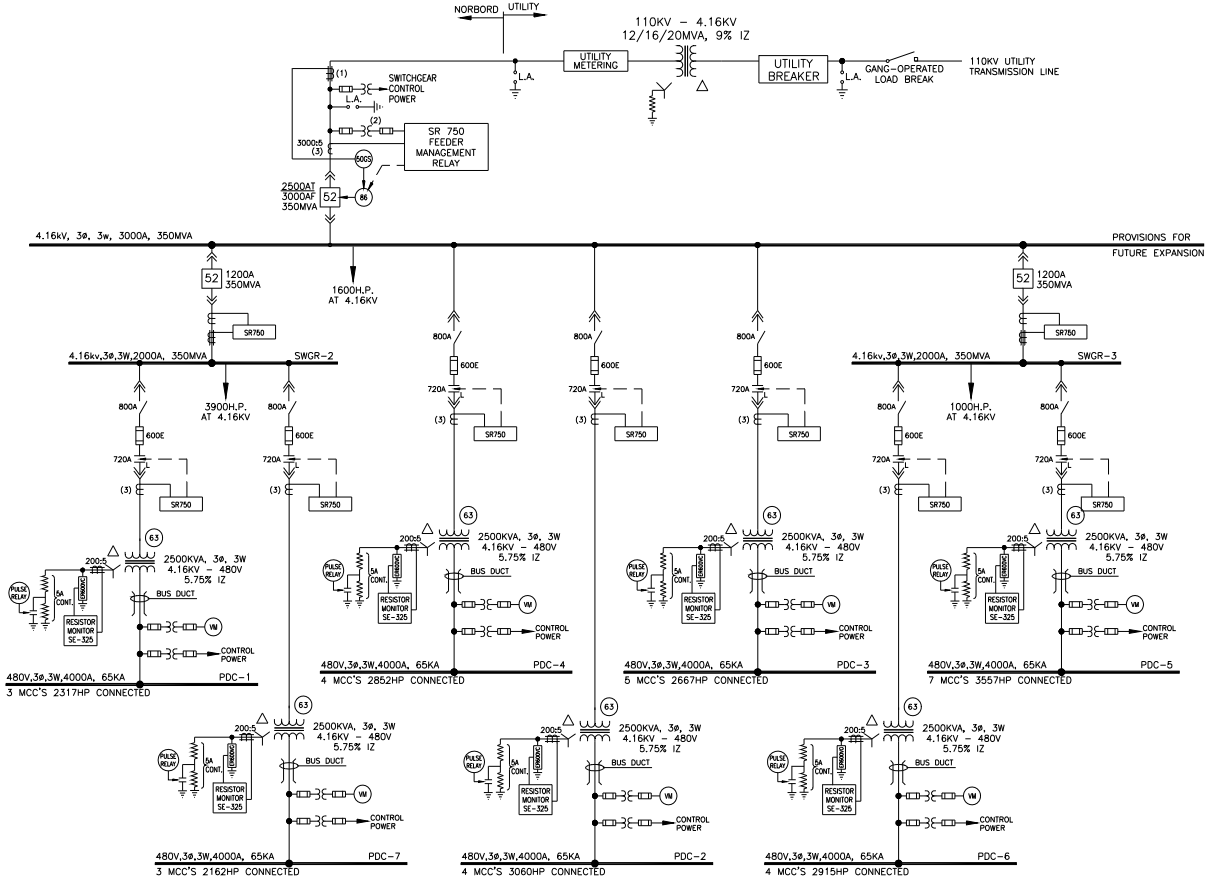

System Specifications:

- 26,000 HP Connected
- 12/16/20MVA, 110kV - 4.16kV Transformer
- 800 HP Motors
- Three 4.16kV Switchgear Lineups
- 1 - 3000A Main Circuit Breaker
- 7 - 720A Fused Vacuum Circuit Breakers
- 2 - 1200A Circuit Breakers
- 7 - 2500kVA 41600 - 277/480V Transformers
- 7, 5A, 277V High Resistance Grounded Systems c/w Startco SE-325 Relays
- 7 - 4000A, 65kA, 480V PDCs
- 30, 480V M.C.C., 1200A & 1600A Bus, 65kA Bracing
- 900kW Emergency Generator
- 10 SR750 Multilin Relays
- 12 269 Multilin Relays

For further information or to contact a Hinz office near you, please check our website at:

www.hinz.com