



A Rockwell Automation Company

Trus Joist MacMillan Deerwood PSL-300 - Plant Floor Order Entry System

The Client:

Trus Joist MacMillan (TJM) is a limited partnership formed in 1991 between MacMillan Bloedel's Engineered Wood Division and Trus Joist International to manufacture high quality Engineered Wood

Products. The new plant in Deerwood Minnesota was to be the first of its kind in the world to produce a new product called Parallel Strand Lumber (PSL-300TM).

The Requirement:

Ten years of research by MacMillan Bloedel had produced a new and exciting engineered wood product called Parallel Strand Lumber (PSL-300TM). After extensive pre-production research and testing, it was time to build the first full-scale production facility for this new product. The production of PSL-300 involved pressing strands of wood into large mats or boards. Boards produced by this process are cut into finished product by an automated sawing system. Production of the boards is very costly and a just-in-time manufacturing system with no inventory was a very

important requirement. Production of product is based on orders received, and cutting the board into specific products could cover several orders.

An interface between the business system and the plant floor controllers was required. The plant floor controllers are Allen-Bradley PLCs and the business system is an HP 3000. The business system accepts orders and produces cutting instructions for the automated sawing line. Orders must be tracked, filled, labeled, and reported by the production system.

The Design Solution:

Hinz was contracted to provide communication to the plant floor and management of the order processing and tracking.

The Plant Floor System (PFS), is an HP 9000 running the UNIX operating system. It communicates to the business system over Ethernet and serial link to the PLCs. The PFS utilizes Xterms for operator interfaces and high speed line printers for large 8.5 x 11 inch bar codes. The application was developed using the RealTime Applications Platform (RTAP) from Hewlett Packard.

The PFS manages orders sent from the business system. The business system sends a cutting schedule to the PFS for the daily production schedule. The PFS communicates the cutting instructions to the PLCs and tracks the products through the system to the packaging line. As the orders are packaged the PFS

produces a packing list and order information on a bar code printer which is to be affixed to the package. The PFS communicates the production information back to the business system.

The plant floor operator can control the cutting schedule and production activity from the operator console. Orders can be suspended, changed, or deleted from the list. New or special orders can be added into the system by selecting them from a supplied list or an operator can compose a new cutting pattern.

The packaging line operator can request information on orders in the schedule, orders being cut and packaged, or on the history of completed orders. The most common usage of the packaging line operator console is to reprint labels.



A Rockwell Automation Company

Trus Joist MacMillan Deerwood PSL-300 - Plant Floor Order Entry System

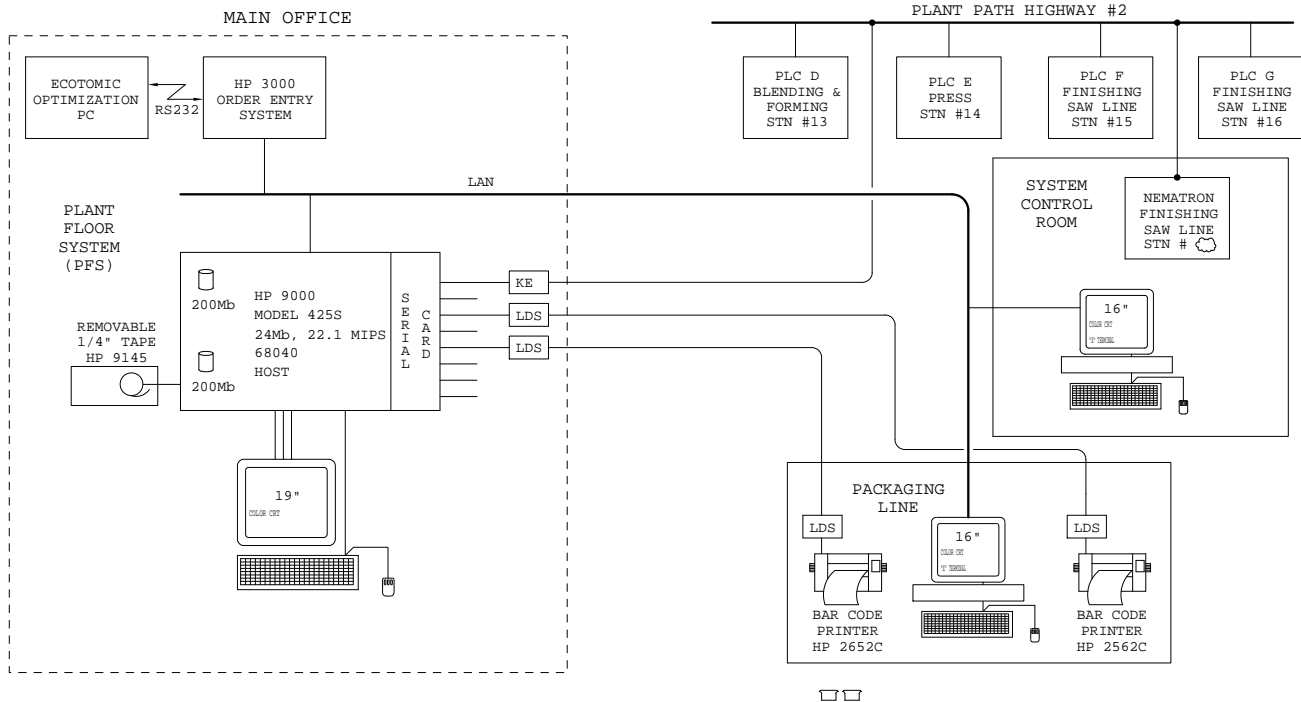

System Specifications:

- HP-9000 Unix Workstation Host
- Ethernet Connectivity to HP-3000
- X-Terminal Operator Interfaces
- Allen-Bradley PLC 5 with 600 Tags
- Product Identification and Bar Coding
- Hewlett-Packard's Real Time Applications
- Platform (RTAP) Solution

For further information or to contact a Hinz office near you, please check our website at:

www.hinz.com