



## **Hinz Automation Inc.**

### **Norcen Energy Resources - Fort Saskatchewan**

### **Controls Upgrade Moore APACS**

#### **The Client:**

Norcen Energy is active in the Oil and Gas industry throughout Alberta. One of their plants, the Fort Saskatchewan Liquid Extraction Plant, processes raw gas from the Westlock and Cherhill fields. The plant inlet is 35 million standard cubic feet per day at 3100 kPa. The plant primarily produces ethane for nearby plants - Sherritt Gordon, Chevron, and Amoco. To meet market demands it can also operate in a propane production mode.

The inlet gas is dehydrated to 106 kg per million cubic meters. Then the gases are separated and chilled. The methane is stripped of the demethanizer then compressed and shipped. The ethane plus components are stripped off the bottom of the demethanizer and stored on site.

#### **The Requirement:**

This gas plant was initially commissioned in August 1984. The originally installed Fisher Provox DCS has aged sufficiently to warrant the DCS upgrade. The control system replacement was based on the following.

- Elimination of obsolete equipment.
- Installation of a modern control system providing easy access to spares.
- A new system could provide a Graphical User Interface (GUI) structure making configuration modifications for site personnel an easy task.
- Installation of a new DCS system would provide access to quicker response (Realtime) graphics displays.
- The new DCS could provide Historical Trends and Realtime Trends for the operators.

#### **The Design Solution:**

The new system consists of a Moore APACS Distributed Control System (DCS). It provides control of all process related plant functions and alarms. It also interfaces to an existing PLC that provides the shutdown key sequence for the plant. Phase II of this project involves the removal of the existing PLC allowing its I/O to be integrated into the APACS system.

The Moore DCS system controls 34 PID loops and monitors 30 additional analog points. Control scan time upon the completion of commissioning is 9 milliseconds for the entire system.

The APACS system incorporates two (2) industrial control processors. One (1) is based on the Motorola 68030 and is used for execution of the control logic. The other processor is based on INTEL's 80486DX33 architecture for the Graphical User Interface (GUI).

This installation has a backup control processor and a backup graphics processor to provide 100% redundancy.

The GUI uses Microsoft Windows, a multi-tasking environment, where system configuration can be done concurrently with plant control. The operators control all aspects of the process through either of the two (2) processors and utilize a mouse to interface to the system.

System development of operation and graphics was done with plant personnel involvement through several stages. Installation and commissioning was done as planned during the specified turnaround during May of 1993.



## Norcen Energy Resources Controls Upgrade Moore APACS

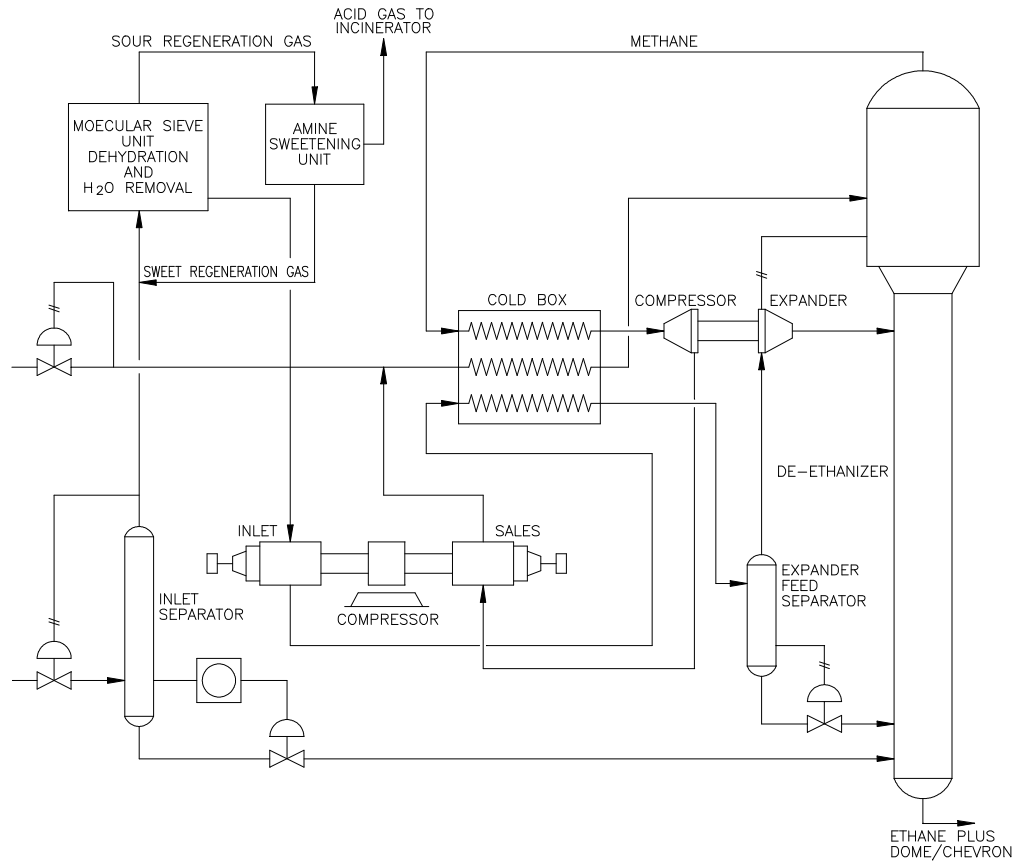

### System Specifications:

- Moore APACS DCS
- Two (2) 20" SVGA Monitors
- 10 Graphics displays
- 34 PID loops
- 23 RTD's
- 10 Analog inputs
- 46 Discrete inputs

For further information or to contact a Hinz Automation office near you, please check our Web site at

[WWW.HINZ.COM](http://WWW.HINZ.COM)